



RÜZGÂR, GÜNEŞ VE DALGA ENERJİSİ ÜÇLÜSÜNÜN HİDROJEN EKONOMİSİNDEKİ YERİ



BAŞKENT UNIVERSITY

Prof. Dr. Birol Kıkış, Fellow ASHRAE
Başkent Üniversitesi ve TTMD

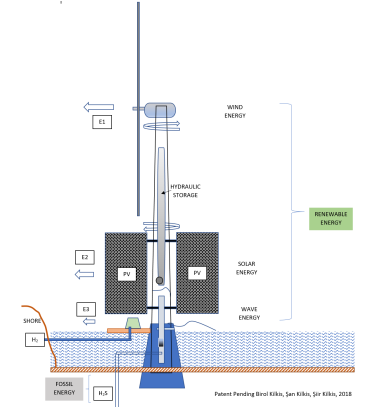

ÖZET

Yenilenebilir enerjideki kavram sorunlarının en başında kaynakların tek tek ele alınmasıdır. Halbuki, bu kaynaklar geniş bir yelpazede harmanlanmalıdır. Dalga enerjisi de bu kapsamda ele alınmalıdır. Bu sunuda dalga enerjisinin de tek başına yeterli olamayacağı vurgulanarak her üçü de kesikli enerji kaynağı özelliği taşıyan dalga enerjisi, güneş enerjisi ve rüzgâr enerjisinin birlikteliğinde hidrojen üretilerek enerji depolamasının olası yararları tartışılmakta ve Trabzon Kenti için bir öneri sunulmaktadır. Ayrıca H₂S yatakları da sisteme dahil edilmektedir.

Bu uygulamada, elde edilen elektrik enerjisinin talepten fazlasının hidrojen üretimi ile depolanması ve talep olduğunda yakıt pilleri ile tekrar elektriğe dönüştürülerek kente arz edilmesi, bu arada ısı pompaları ile de bölge ısıtma ve soğutmasının gerçekleştirilmesi anlatılmaktadır. Bu bağlamda, ikinci bir seçenek olarak bölge sisteminde hidrojen dağıtımı da yapılarak hidrojen evlerinde kullanılması da gündeme getirilmektedir. Örnek bir hidrojen evi tasarımı da tanıtılmaktadır.

WE NEED TO DECLARE..

A RATIO
REVOLU



EARTH
ING TODAY

**THE ENERGY SECTOR MUST RESPOND TO GLOBAL WARMING BY CLIMATE
RESPONSIVE DESIGNS AND APPLICATIONS, WORLD-WIDE**

BİZ İNŞAATLA MEŞGULKEN NEREYE GİDİYORUZ?



BİR RESİM BİN KELİMEYE BEDELDİR

Yenilenebilir enerji ama nasıl ?



ÖN TESPİTLER

(ECOS 2018, ©Birol Kılış)

SÜRDÜRÜLEBİLİR KALKINMA ve CO₂ SALIMLARI

Sürdürülebilir Kalkınma için Enerjiye Gereklimiz var

Human Sustainable Development Index

$$HSDI = cQ^a + dE^b$$

ISI GÜÇ

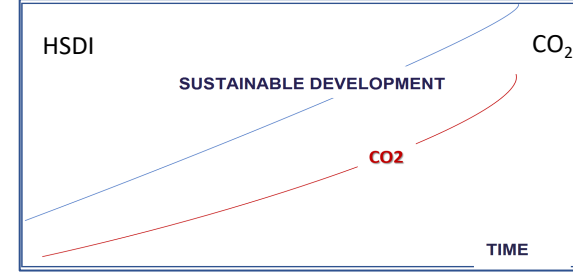

Aynı Zamanda CO₂ Salımları da Enerji Tüketimi ile Orantılı. İşte Asıl Sorun Bu.

SIRA KİMDE

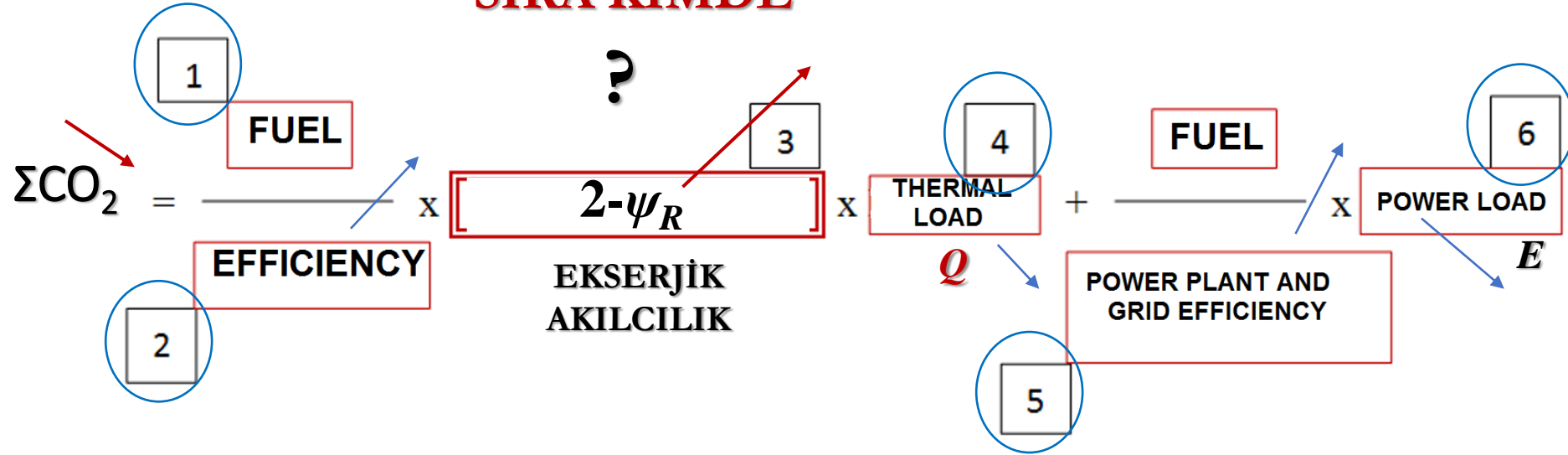

BİRİNCİ YASA MI YOKSA İKİNCİ YASA MI?

$$\psi_R = \frac{\epsilon_{\text{talep}}}{\epsilon_{\text{arz}}}$$

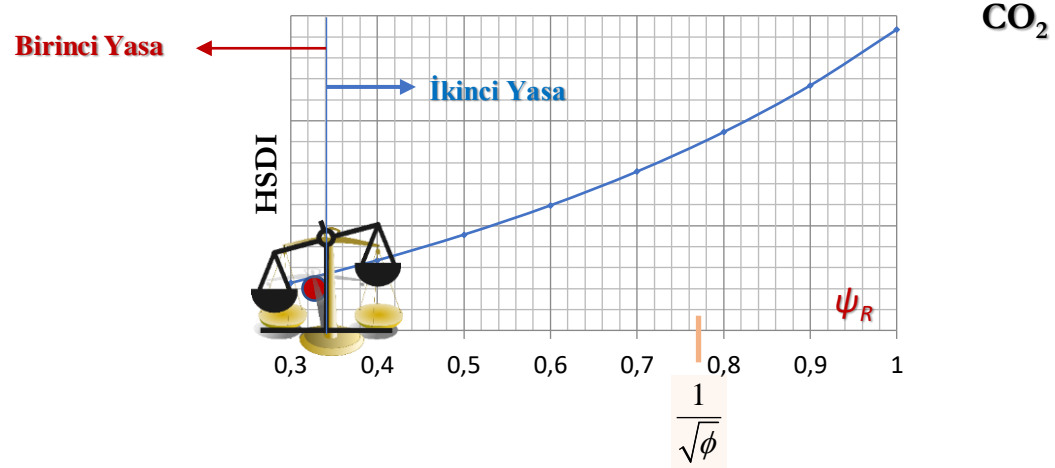

Termodinamiğin 1. Yasası Misyonunu Bitirmek Üzere

SÜRDÜRÜLEBİLİR KALKINMA İLE CO₂ SALIMLARINI AYRIŞTIRMALIYIZ AMA NASIL?

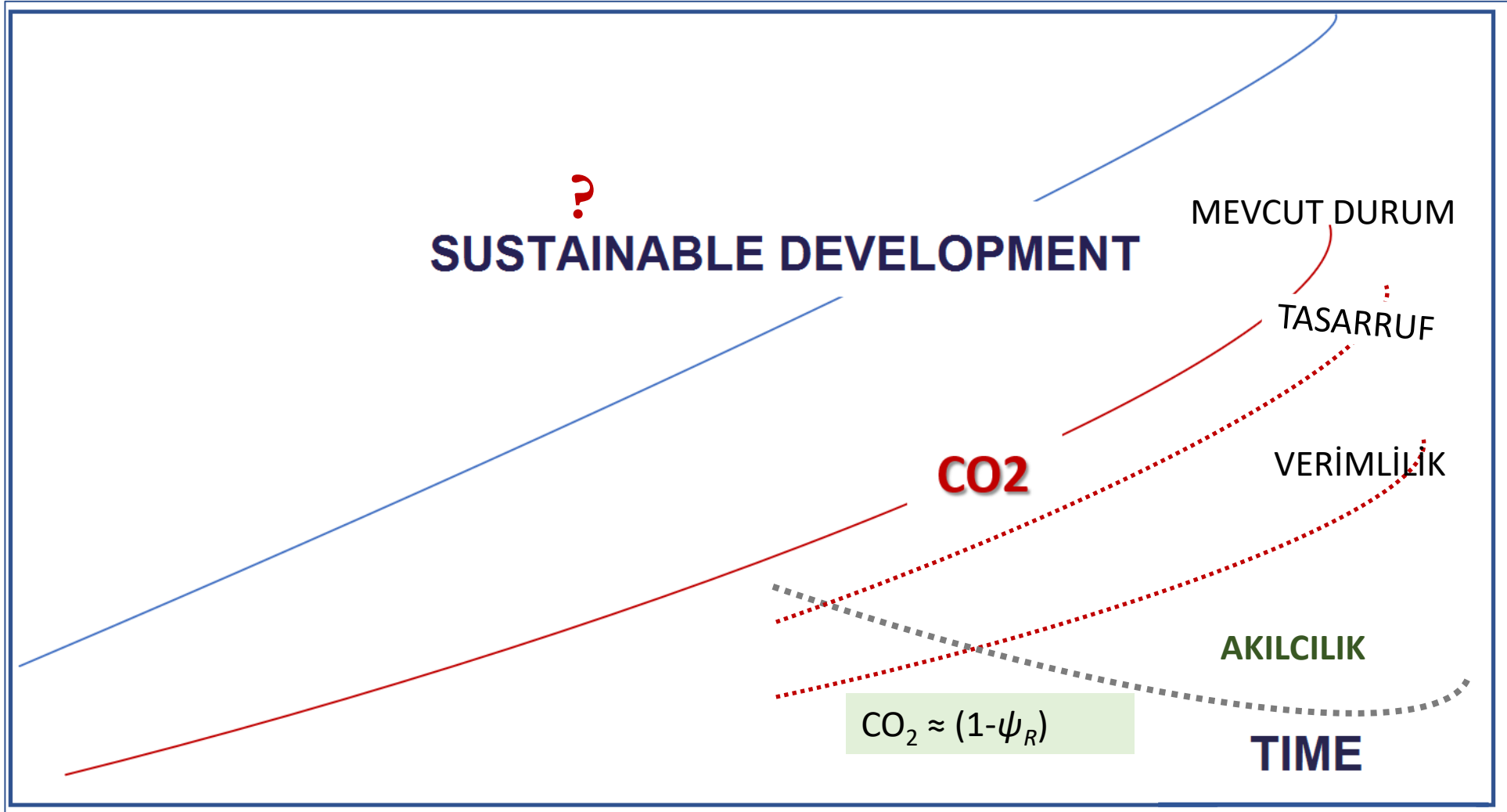

YENİLENEBİLİR ENERJİ KAYNAKLARININ KISITLARI

- Eş-Yersizlik



- Eş Zamansızlık



- Kestirimsizlik



- Kesiklilik

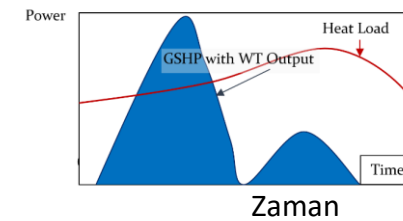
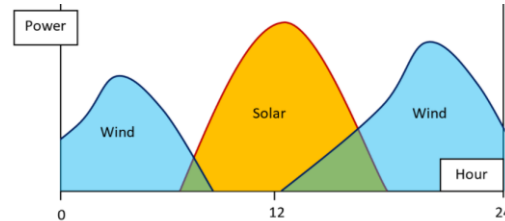

POTANSİYEL GÜÇ YOĞUNLUĞU

Kıyı Bölgesi	Enerji Potansiyeli (1 m enindeki dalga için) kW-h/m
Karadeniz	1,96-4,22
Marmara Denizi	0,31-0,69
Ege	2,86-8,75
Akdeniz	2,59-8,26
İzmir-Antalya	3,91-12,05

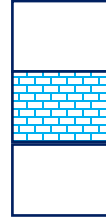

0.40 kW-h/m²

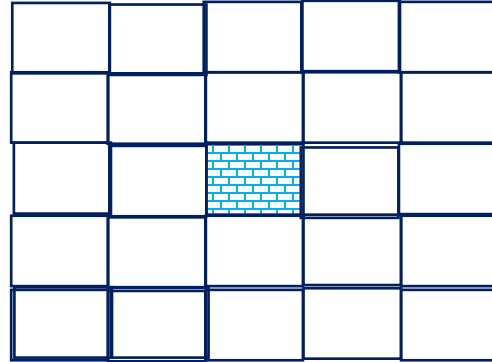

1 kW-h/m²

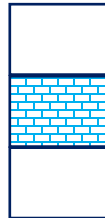

0.05 kW-h/m²

YOL HARİTASI 1

- Melez Uygulamalar

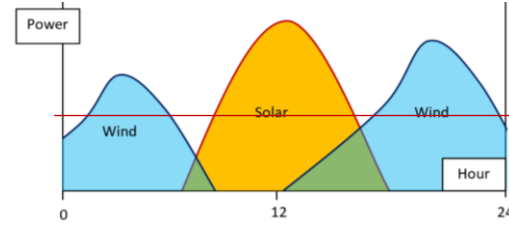

Enerji Depolamasız Sistem

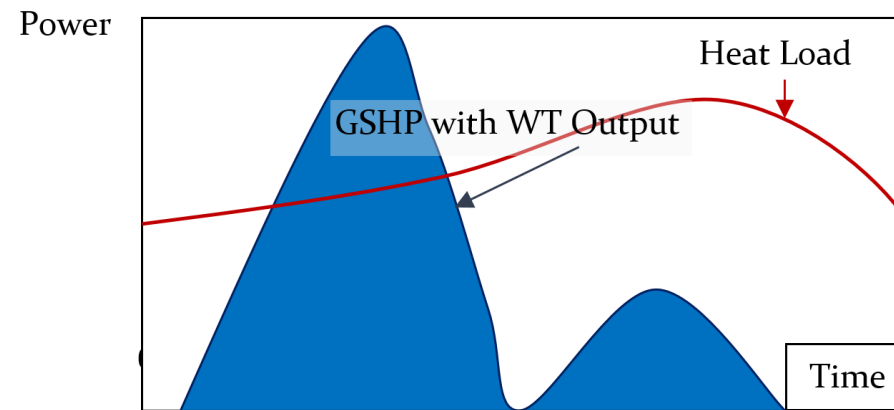
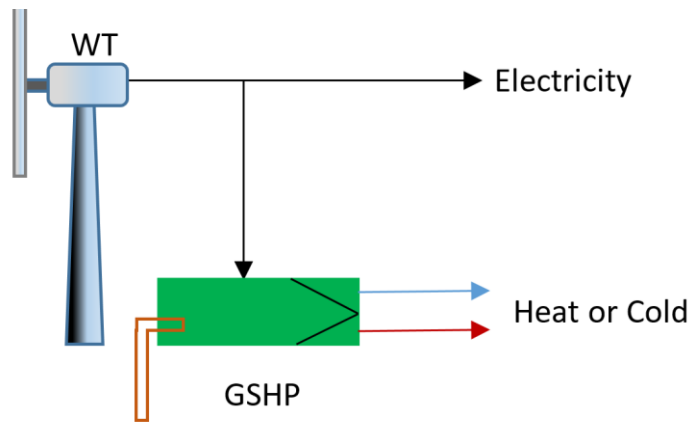

ENERJİ DEPOLAMASI

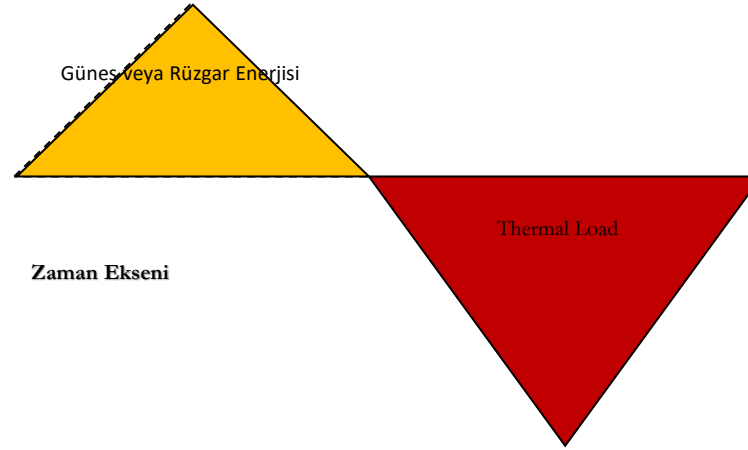

A SYNECTIC OFF-SHORE WIND,
SOLAR, WAVE AND FOSSIL
ENERGY COMBINATION

COMBO SYSTEM FOR BLACK SEA

©Kilkis 2018

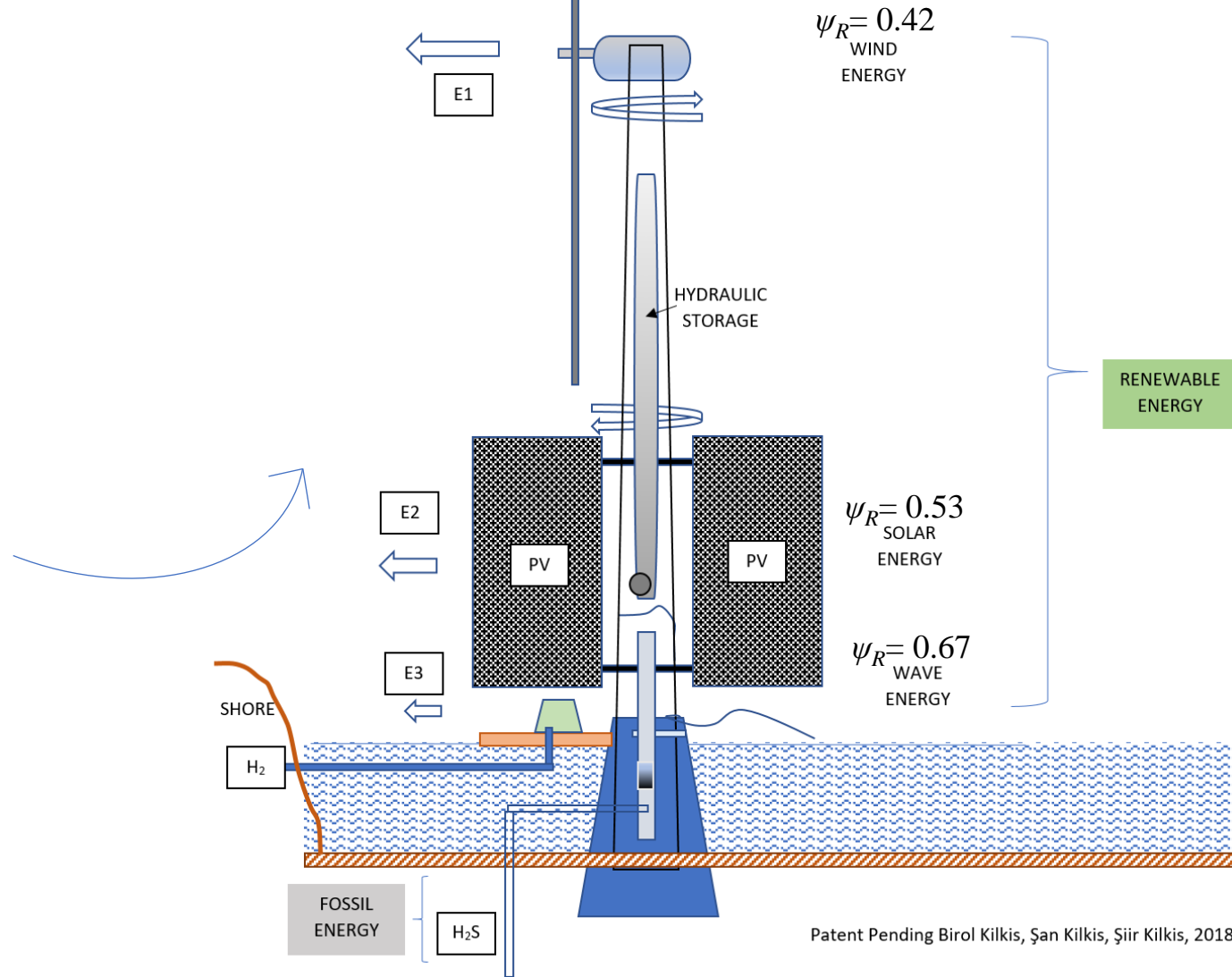

SOLAR ENERGY OF TOMORROW

- Rüzgar
- Güneş
- Dalga
- Jeotermal
- Enerji Depolaması

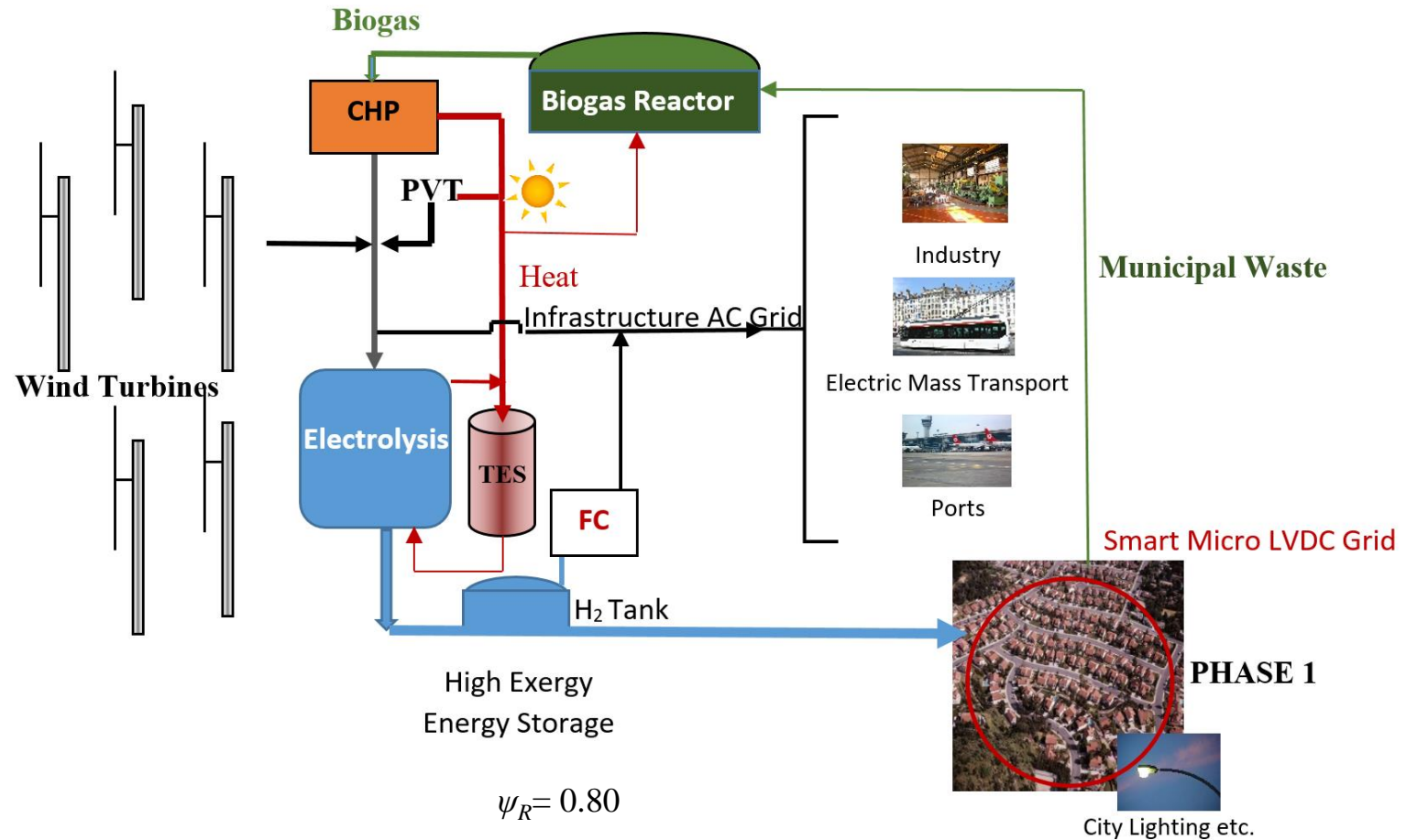

CLOSING THE WATER LOOP

and Generating Fresh Water from the Sea

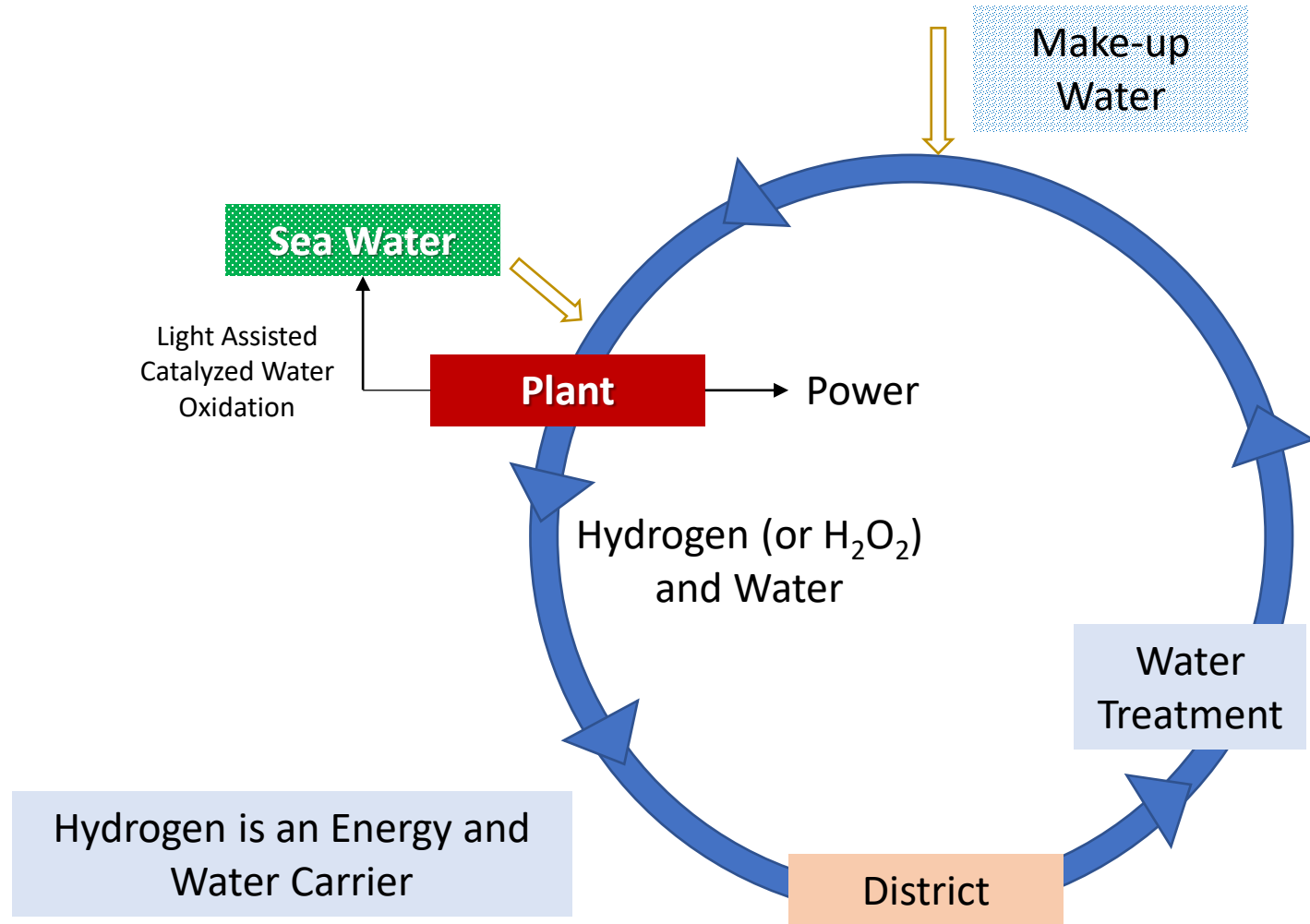
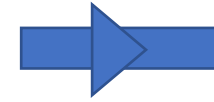

Water recovery may be up to 70% with cooling. Current technologies form Chlorine gas. In order to avoid this new technologies are in the field like light assisted catalysis. If sea is nearby or feasible to transport sea water, fresh water is an important by-product of this system. H₂O₂ may also be feasible to use in the hydrogen loop, while it can be also directly used in Fuel Cells.



All DC-SOLAR-Central Hydrogen Hybrid Net-Zero Exergy Building (NZEXB): Energy-Water- Environment Nexus

Phase 1

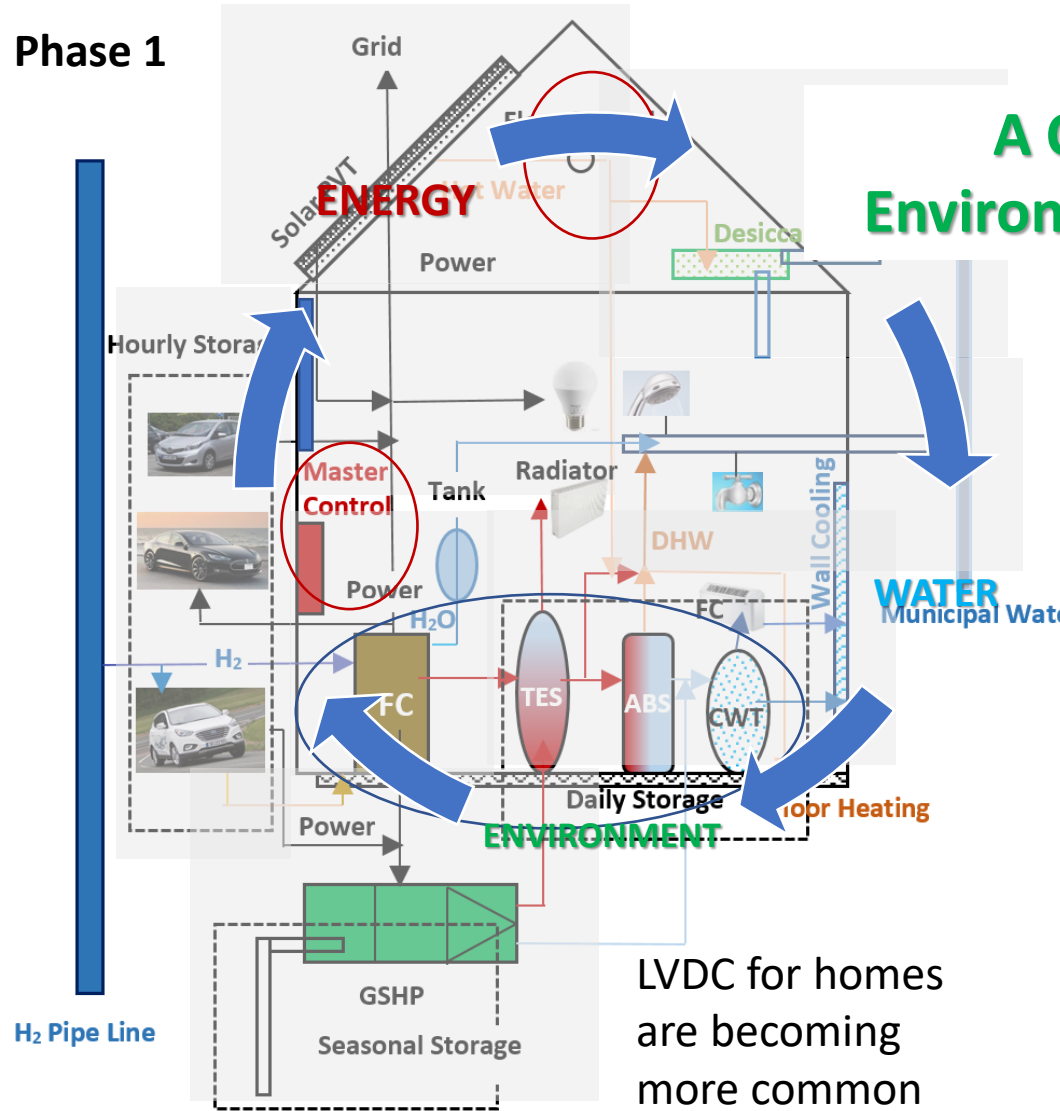

LVDC for homes are becoming more common and safer.

COMMENTS

A Complete Energy-Water-Environment Nexus at Building Level

conditions. Main controls are:

- 1- PVT Flow control
- 2-Master control/optimizer for maximum REMM efficiency so that it is maintained above 70%.
- 3-Individual controls for FC, TES, ABS, and CWT, which are all orchestrated by the Master Control.

cars have disadvantages, if one is parked, its batteries may be charged by the FC system at a much higher efficiency of power conversion using hydrogen gas.

3- **Hydrogen Car:** Parked car receives hydrogen fuel at the building site after pressurization. It may provide back power, water, and heat to the building. Cars are hourly energy storage systems.

HYBRID HYDROGEN HOME

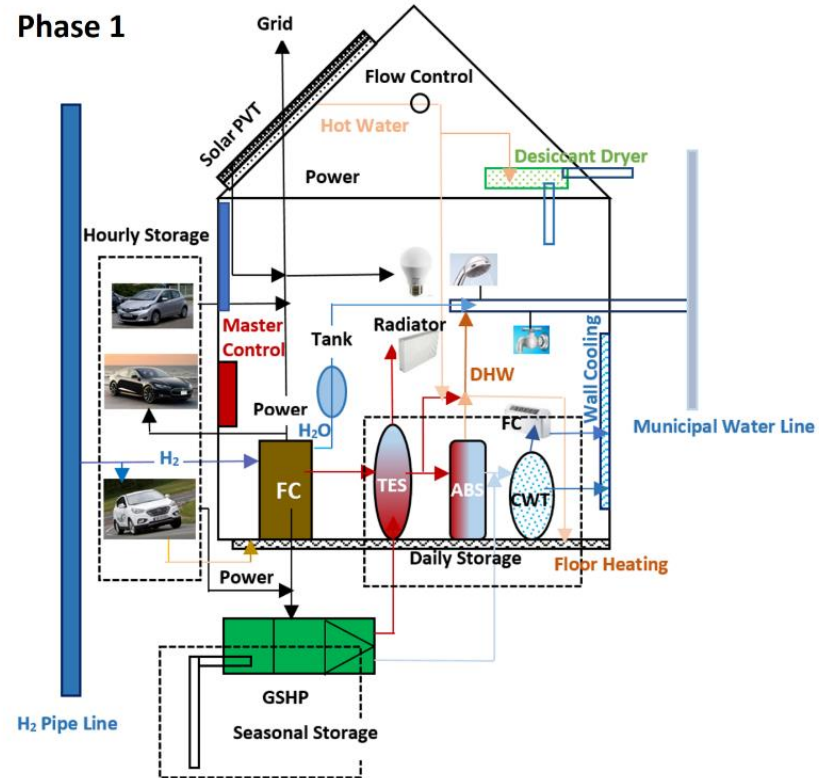

AN OUT-OF-THE BOX SOLUTION

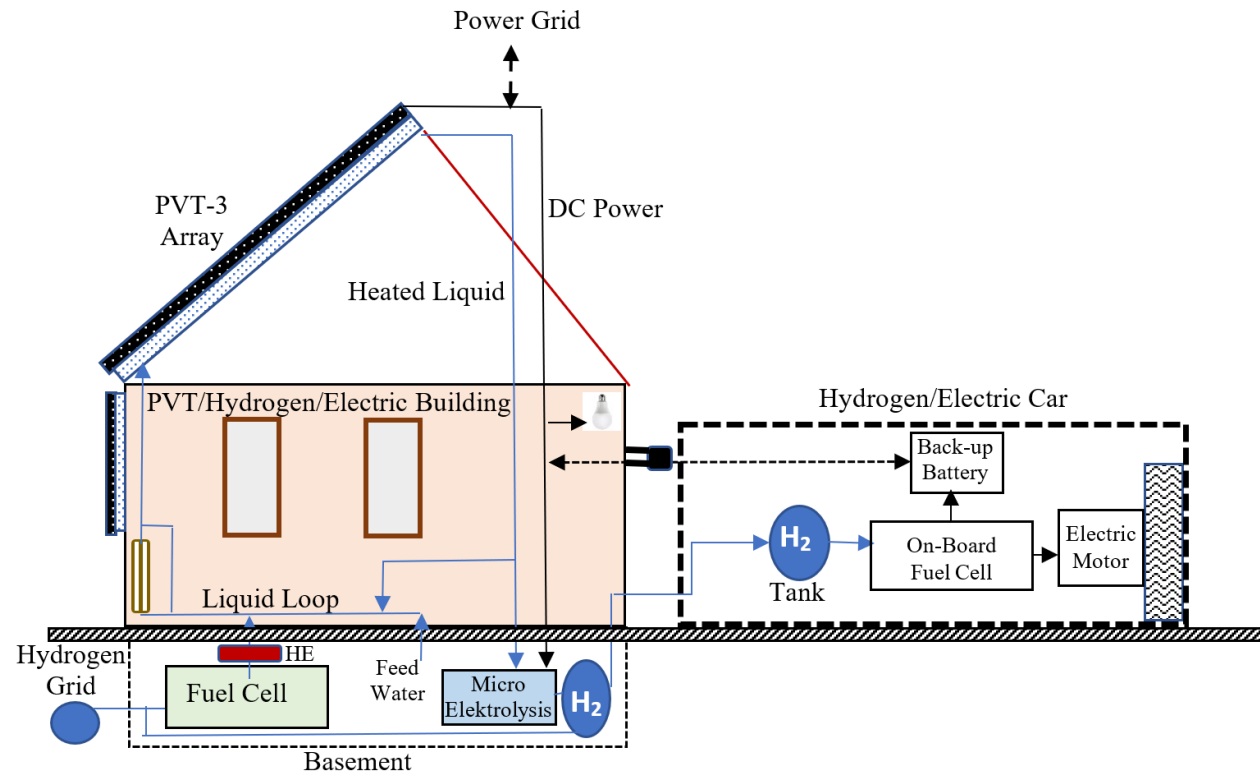

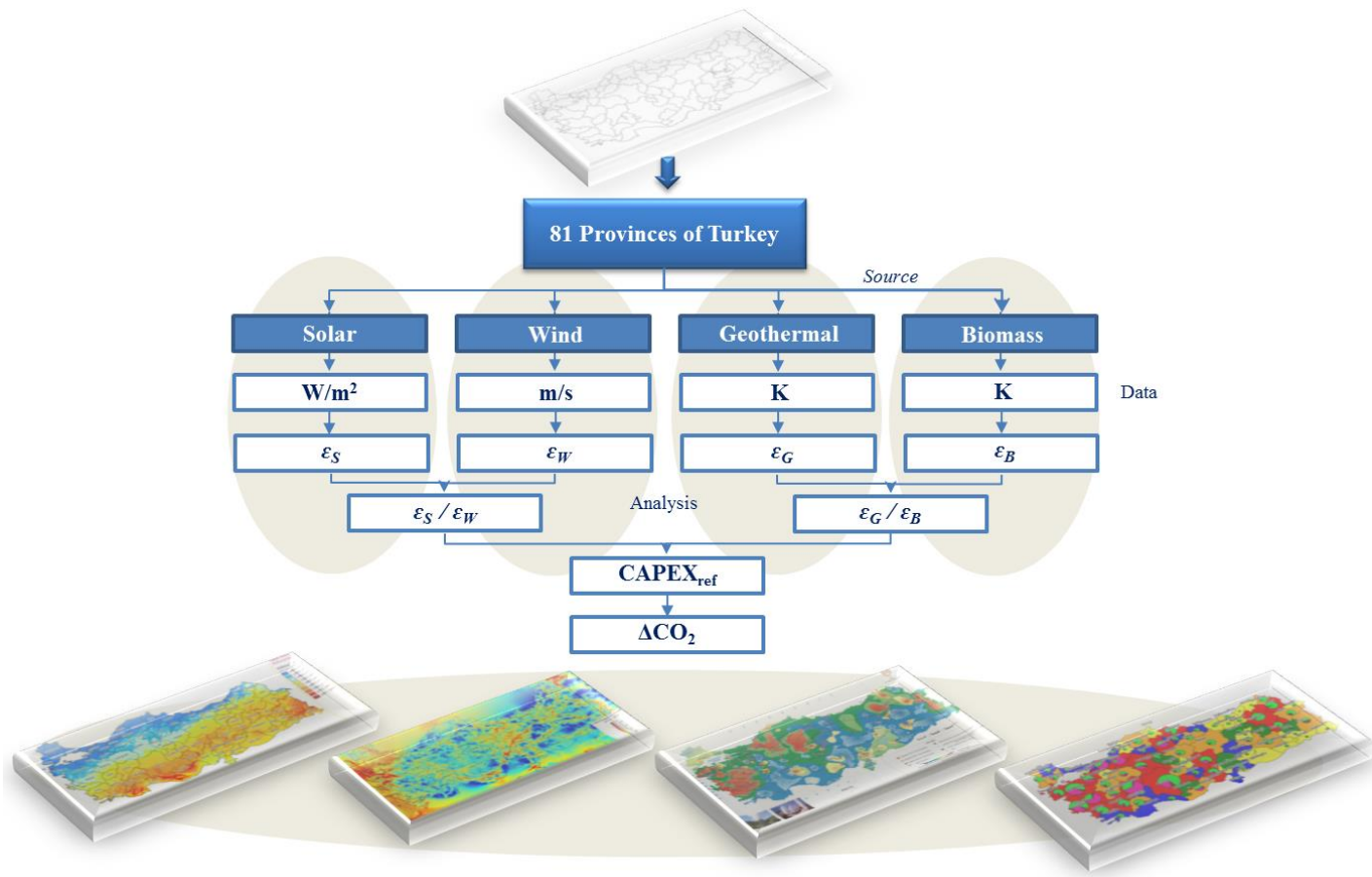

COMPOSITE RENEWABLE EXERGY ATLAS



© Siir Kılıç, 2016

COMPOSITE ATLAS

Exergy-Based Renewable Atlas of Turkey

© 2016 Şiir Kalkış



TURKEY Average

ϵ_S (Solar)	0,35
ϵ_W (WIND)	0,45
ϵ_G (Geothermal)	0,17
ϵ_B (Biomass)	0,76

Her Ezber Bozanın bir Çözümü Vardır

Sizi Bilimsel ve Teknolojik
Farklılıklarımızın Bilincine Varıp Yeni
Fırsatlara Dönüştürmeye Davet Ediyorum.

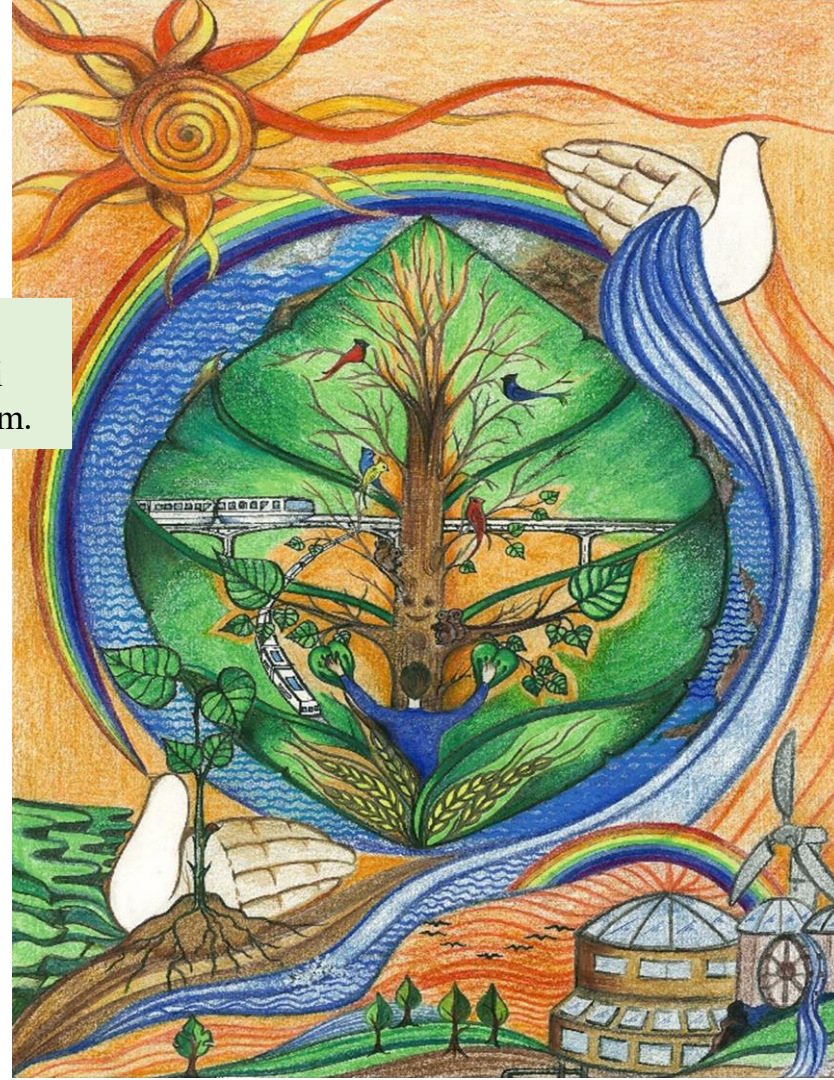

San Kilkis
Unesco Ödülü 2002